



**THINK
INSIDE
THE BOX**

**ALL ABOARD
EDMONTON'S
FIRST SHIPPING
CONTAINER
RETAIL PARK!**



STATION PARK



**ONE OF A KIND
DEVELOPMENT**

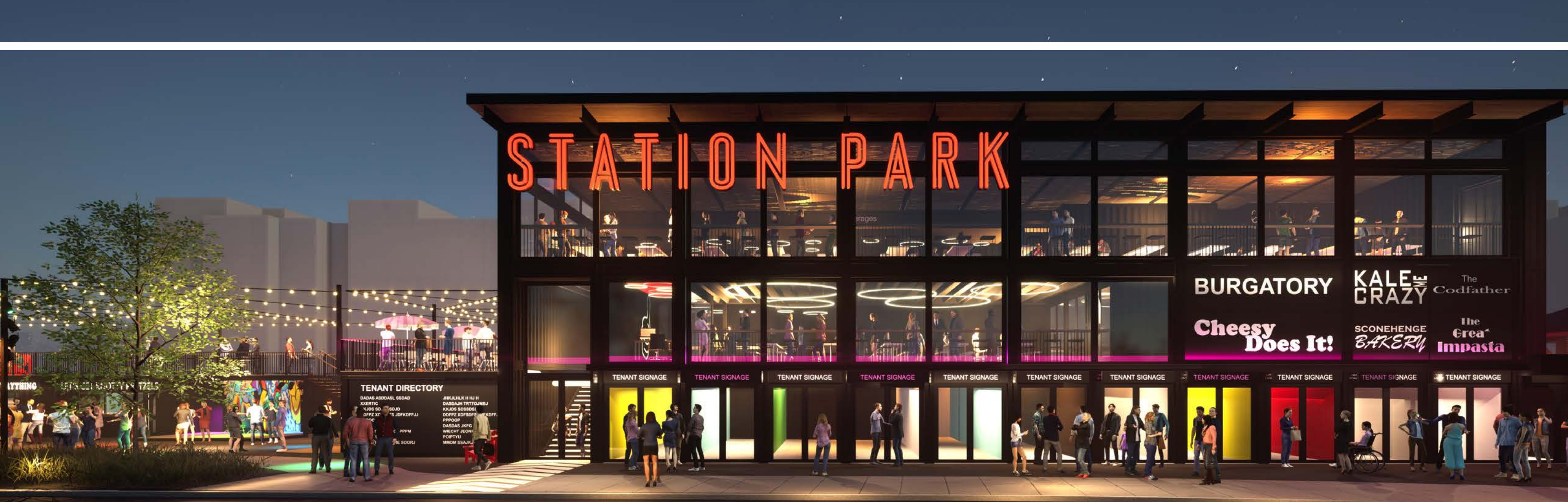

**LOCATED IN THE HEART
OF OLD STRATHCONA**

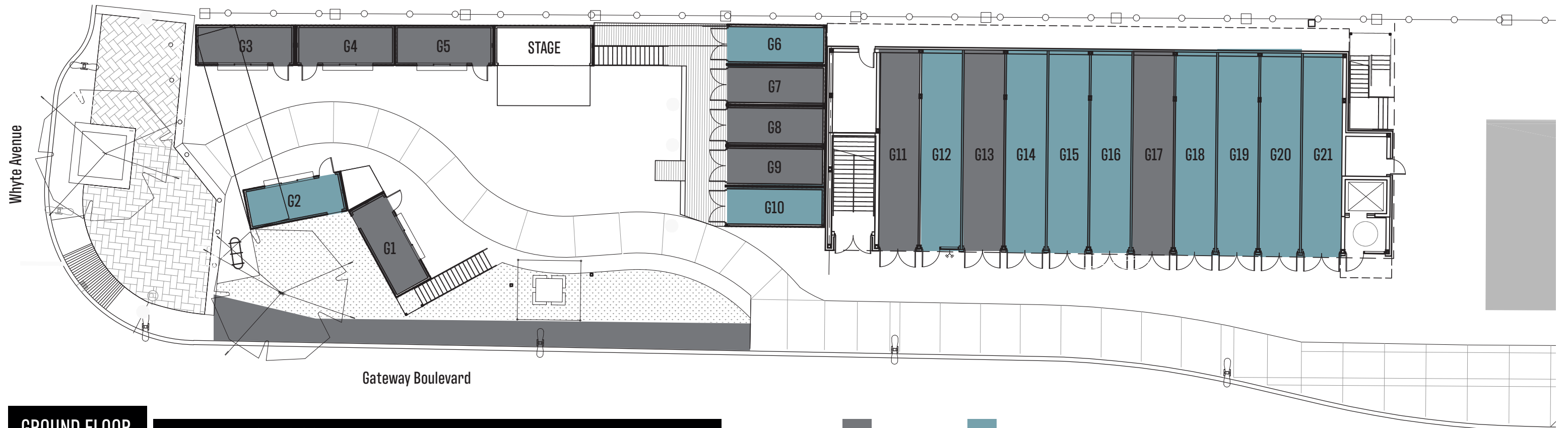

GROUND FLOOR

For Lease: 157 SF to 316 SF

Pending Available

MICRO-RETAIL OPPORTUNITIES

HONOURING THE STORIED HISTORY OF THE CPR RAIL LINE

ON BOARD AMENITIES:
 Serviced units that can accommodate retail, personal service, and food and beverage uses.

SECOND FLOOR

Food Hall

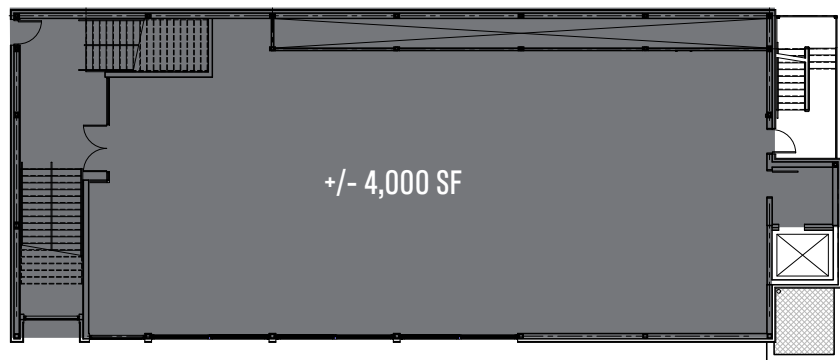

THIRD FLOOR

Events Space and Bar



Photos on this page for visualization purposes only

FOOD HALL + EVENT SPACE

ON BOARD AMENITIES:
Patio space access off the second floor, elevator, signage and excellent frontage onto Gateway Boulevard.



**ARRIVING
SPRING 2023**

STATIONPARK

Beljan

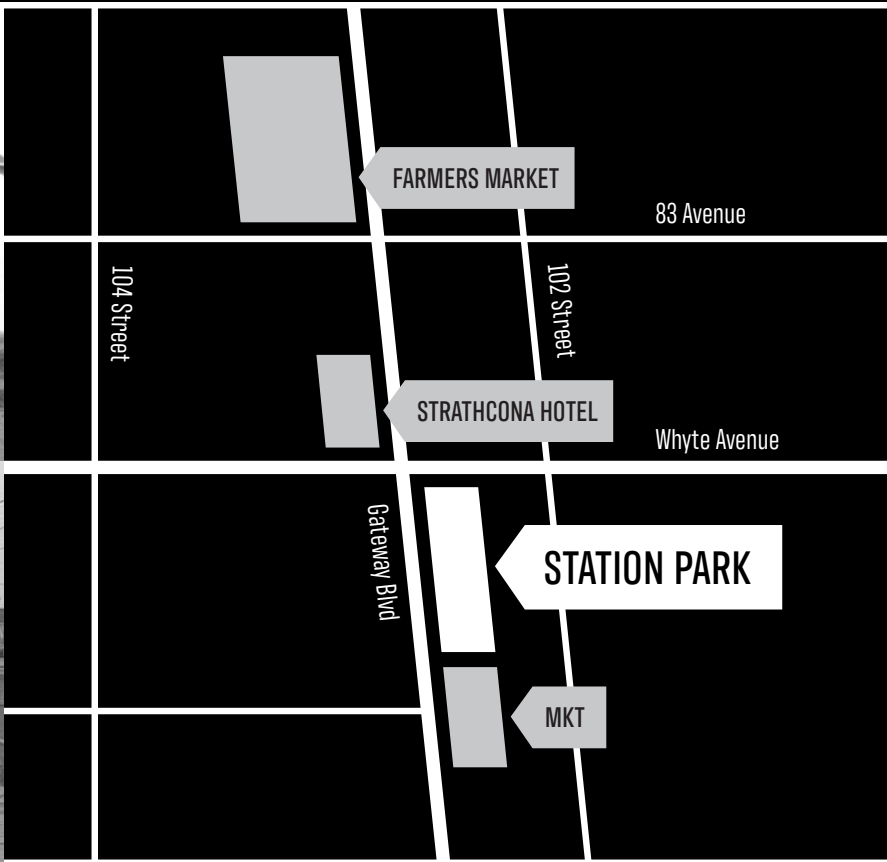

PUNCH YOUR TICKET!

STATIONPARKYEG.COM

Akeem Brown - Conductor
780 915 4402
akeem@stationparkyeg.com

INFO@STATIONPARKYEG.COM

Dave Hennessey - Operator
780 966 0642
dave@beljanddevelopment.com